

CASCADING APPLICATION INFORMATION

Teledyne Cougar's comprehensive line of cascading amplifiers includes many multiple stage amplifiers where some of the cascading has been integrated into a single package. This process makes the job of achieving high gain easier, saves money and space, and usually achieves a superior result, particularly when considering SWR and gain flatness.

An example of a multiple-stage amplifier in a single package is the AC1066, as seen in the diagram to the right.

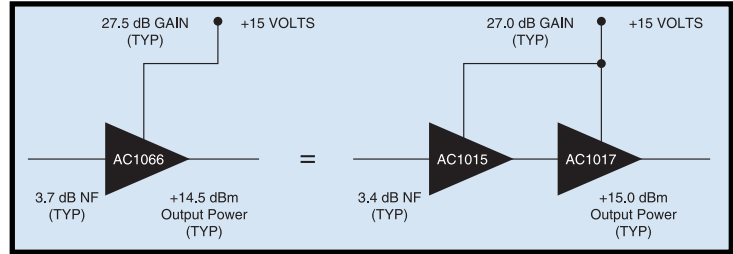

Gain

The total minimum cascaded gain will equal the sum of the individual minimum gain. See the equation to the right. For a conservative worst case, subtract 1 dB from this sum. In actual practice with Cougar amplifiers, the cascaded gain will be very close to the sum of the individual typical gains.

$$14 \text{ dB} + 14 \text{ dB} + 9 \text{ dB} = 37 \text{ dB}_{\text{min}}$$

$G_{1\text{min}} \quad G_{2\text{min}} \quad G_{3\text{min}}$

Gain Flatness

Cougar amplifiers are typically flat to within ± 0.15 dB. The cascaded gain will typically be less than ± 0.5 dB for all amplifiers that operate up to 2.0 GHz. A cascaded specification of ± 1.0 dB maximum is generally achievable.

Noise Figure

The first stage noise figure F, will increase as shown by the equation to the left. F₁ is the uncascaded first stage noise factor, F_n is the Nth stage noise figure, and G_n is the gain of the Nth stage amplifier. An amplifier with 3.0 dB noise figure and 15 dB gain cascaded with a second stage amplifier that has 5.0 dB noise figure will increase to approximately 3.15 dB noise figure.

$$F = F_1 + \frac{F_2 - 1}{G_1} + \dots + \frac{F_N - 1}{G_1 G_2 \dots G_{N-1}}$$

Return Loss

Most of Cougar's amplifiers that operate to 1500 MHz are designed to have a cascaded SWR of less than 2.0:1. The typical cascaded SWR is 1.5:1 or better. Amplifiers that operate above 1500 MHz will cascade with SWRs that typically will be less than 2.0:1, but should be specified at 2.2:1. Tighter specifications can be achieved as shown by the cascaded example in Table IV (next page), when special matching is required.

Output Power

The cascaded output power will equal the power of the output stage when applying the following expression, which is used for specifying the drive stages.

$$P_{\text{drive}_{\text{min}}} = P_{\text{output stage}} - \text{Gain output stage} + 4\text{dB}$$

Intercept Point

The Nth order output intercept point can be determined using the expression to the left. RdB is the relative suppression of the Nth order product in dB, and P_{out} is the output power level. Cougar's AP348, at 100 MHz, typically shows RdB = -66 dB with +10 dBm output for third order two-tone (see the following expression).

$$I.P. = \frac{R_{dB}}{N-1} + P_{out}$$

$$I.P. = \frac{66}{3-1} + 10 = +43 \text{ dBm}$$

If the output intercept point is known, then relative suppression can be calculated using the equation to the right.

$$R_{dB} = (n-1)(I.P. - P_{out})$$

Intercept Degradation

For best linearity, the I.P. required of the drive amplifier can be calculated using the equations shown in Tables I and II.

The output I.P. of the driver stage must be at least 3 dB greater than the input I.P. of the output stage. If less than 3 dB separation is used, the result will be greater than 1 dB degradation. For 0 dB separation, the degradation will be 3 dB in the output intermodulation levels.

For best linearity in IP3 use a drive amp with an IP3 ≥ 6 dB higher than the input IP3 of the output amp. See Table I.

TABLE I

IP3 LINEARITY	Example IP3 Amp 1	IP3 Amp 2	Final IP3 Output	Reduction in IP3
IP3 drive stage = IP3 output stage – Gain output stage + 6 dB	32	36	35	1.0 dB
IP3 drive stage = IP3 output stage – Gain output stage + 3 dB	29	36	34.2	1.8 dB
IP3 drive stage = IP3 output stage – Gain output stage + 0 dB	26	36	33	3.0 dB

For best linearity in IP2 use a drive amp with an IP2 ≥ 10 dB higher than the input IP2 of the output amp. See Table II.

TABLE II

IP2 LINEARITY	Example IP2 Amp 1	IP2 Amp 2	Final IP2 Output	Reduction in IP2
IP2 drive stage = IP2 output stage – Gain output stage + 10 dB	60	60	57.6	2.4 dB
IP2 drive stage = IP2 output stage – Gain output stage + 6 dB	56	60	56.5	4.5 dB
IP2 drive stage = IP2 output stage – Gain output stage + 0 dB	50	60	54	6.0 dB

The examples in Tables III and IV show 2000 MHz cascades using Cougar TO-8 and TO-8B modules to achieve 1 Watt of output power. These examples demonstrate the high degree of cascading available from Cougar's devices across the band.

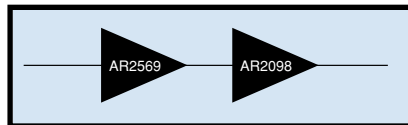

TABLE III: 1 WATT P_{OUT} CASCADE

FREQUENCY MHz	VSWR IN	VSWR OUT	GAIN dB	GROUP DELAY τ_1 SEC	REV/ISO dB
30.0	1.1	1.5	27.3		48.7
100.0	1.1	1.5	27.7		52.8
200.0	1.1	1.6	27.8	0.980	54.0
300.0	1.1	1.7	28.0	0.999	52.9
400.0	1.1	1.7	28.1	0.990	52.2
500.0	1.3	1.6	27.9	0.970	65.2
600.0	1.4	1.5	27.7	0.956	57.4
700.0	1.4	1.3	27.5	0.924	46.8
800.0	1.4	1.2	27.3	0.911	56.7
900.0	1.4	1.1	27.3	0.909	52.4
1000.0	1.3	1.1	27.3	0.899	59.3
1100.0	1.3	1.1	27.5	0.925	58.0
1200.0	1.3	1.2	27.7	0.959	47.2
1300.0	1.3	1.2	27.9	0.969	52.0
1400.0	1.4	1.2	27.9	0.990	52.6
1500.0	1.4	1.2	27.8	0.990	60.2
1600.0	1.4	1.2	27.7	0.999	44.6
1700.0	1.4	1.2	27.6	0.979	45.6
1800.0	1.3	1.2	27.6	0.991	55.1
1900.0	1.3	1.2	27.5	1.002	55.7
2000.0	1.2	1.3	27.5	1.054	46.6

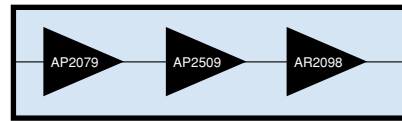

TABLE IV: 1 WATT P_{OUT} CASCADE

FREQUENCY MHz	VSWR IN	VSWR OUT	GAIN dB	GROUP DELAY τ_1 SEC	REV/ISO dB
10.0	1.30	1.68	29.6		57.5
50.0	1.31	1.55	30.9		56.8
100.0	1.29	1.57	30.9	1.721	57.1
200.0	1.26	1.56	30.6	1.232	57.1
300.0	1.26	1.61	30.6	1.158	56.5
400.0	1.30	1.67	30.8	1.165	57.1
500.0	1.39	1.69	30.7	1.181	56.6
600.0	1.48	1.65	30.6	1.178	57.5
700.0	1.54	1.53	30.2	1.145	57.5
800.0	1.54	1.36	30.0	1.119	58.4
900.0	1.50	1.20	29.8	1.101	58.3
1000.0	1.46	1.10	29.8	1.104	58.4
1100.0	1.47	1.12	30.0	1.126	58.0
1200.0	1.48	1.17	30.1	1.155	57.4
1300.0	1.50	1.19	30.2	1.177	57.1
1400.0	1.48	1.20	30.2	1.180	57.4
1500.0	1.42	1.18	30.3	1.199	56.8
1600.0	1.34	1.19	30.3	1.209	56.1
1700.0	1.30	1.26	30.4	1.228	56.3
1800.0	1.30	1.39	30.6	1.293	55.8
1900.0	1.36	1.54	30.6	1.319	55.4
2000.0	1.52	1.71	30.6	1.398	55.6
2100.0	1.79	1.91	30.2	1.461	56.7

AMPLIFIER SENSITIVITY

The minimum detectable signal (MDS) at the input of an amplifier will produce a detectable output signal just above the noise level. MDS is expressed in dBm through the following equation, where B is the bandwidth of the amplifier system in MHz, and NF is the amplifier's noise figure.

$$MDS = -114 \text{ dBm} + 10 \log\left(\frac{B}{1 \text{ MHz}}\right) + 10 \log\left(10^{\frac{NF}{10}} - 1\right)$$

DYNAMIC RANGE

The true dynamic range (TDR) of an amplifier is the range of input signals where spurious outputs are below the noise level of the output. The true dynamic range may be calculated using the following expression. MDS is the minimum detectable signal as determined by amplifier sensitivity above.

$$TDR = \frac{2(I.P. - G - MDS)}{3}$$

PHASE NOISE

Amplifier phase noise typically has two distinct regions. These are the "1/f" region and the flat region. This is depicted in the figure shown at right.

The phase noise spectrum (expressed in dbc per hertz) in the "one over f" region is a function of the physics of the active device, and is generally (though not always) independent of output power as long as the device is operated in the linear region. Here, the phase noise power spectrum is lowered by a factor of 2 each time the Fourier frequency is doubled, hence giving rise to its "1/f" designation. This 3 db per octave behavior extends out to where the noise spectrum becomes essentially flat. Here, the phase noise (unlike in the 1/f region) does depend on output power. This is because the input power to the amplifier is unavoidably accompanied by thermal noise, which at room temperature is known to be: -174 dbm/hz. Relative to the output, this noise is degraded by the amplifier's noise figure. Also, only half of this noise is phase noise; the other half being AM noise. This effect reduces the PM part of the thermal noise to -177 dbm/hz. Therefore, the phase noise in the flat region can be predicted by the following formula:

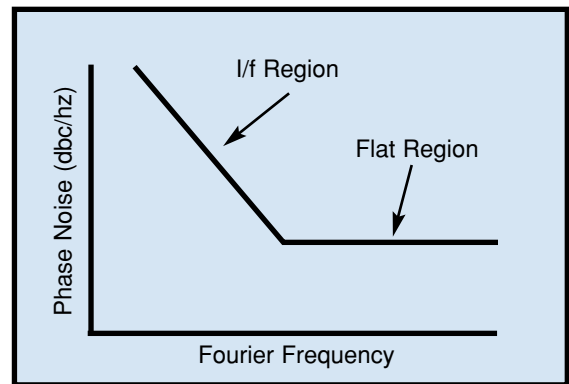

$$Phase \text{ Noise (dbc/hz)} = -177(\text{dbm/hz}) - P_{out}(\text{dbm}) + Gain(\text{db}) + NF(\text{db})$$

This noise is principally due to thermal noise which we have no control over, but can be improved (made smaller) by increasing the output power, decreasing gain or decreasing the noise figure.

SMA CONNECTORIZED 0.1-5000 MHz AMPLIFIERS

Cougar supplies both the standard TO-8 and the larger TO-8B pin packages in SMA RF connectorized packages. To obtain any single TO-8 product with SMA RF connectors add a “C” suffix to the generic model number. For example, model AC2066 in a SMA connectorized case becomes model number AC2066C. For models that use the larger TO-8B header add a “B” suffix. Thus, model AR2036 becomes AR2036B.

For higher frequency models (above 5000 MHz), Cougar offers the CougarPak®. Model AS6043 would become ACP6043 in a CougarPak®. For higher gain applications, cascaded TO-8s are offered using the multiple unit housings.

Literally hundreds of cascade combinations are possible. Several cascaded models, complete with catalog model numbers, are listed in the model selection charts. Our sales staff and engineers can quickly define combinations to meet your tough requirements using computer programs. Call today for quick and accurate cascading application support.



A2CP6008

92 DB Typical Dynamic Range



ACP8017

+21.5 dBm Typical Output Power

DC BLOCKS

Most Cougar models have internal DC blocking capacitors at the RF input and output ports. Please contact the factory for information on specific models.

THERMAL JUNCTION TEMPERATURE

Each amplifier data sheet lists the model’s junction temperature rise above case. Cougar determines junction temperature by applying the actual DC power dissipation of the die to its respective thermal resistance to case. Given the die size and location on the substrate, and its attach method, Cougar calculates the substrate to header thermal resistance for all amplifiers using physical math models.

Thermal resistance (θ_{jc}) is expressed as T_{rise} divided by Total Power.

$$\theta_{jc} = \frac{T_{rise}}{Total\ Power}$$

T_{rise} equals the DC power on the die multiplied by the amplifier’s total thermal resistance ($\theta_{jcTotal}$). See the equation below. Total Power represents the total amplifier DC power dissipation.

$$T_{rise} = (DC\ Power\ on\ die)(\theta_{jcTotal})$$

An amplifier’s total thermal resistance ($\theta_{jcTotal}$) is the sum of θ_{jcDie} and $\theta_{jcStructure}$,

$$\theta_{jcTotal} = \theta_{jcDie} + \theta_{jcStructure}$$

where $\theta_{jcStructure}$ is represented by the following equation and $\theta_{jcInterface}$ represents the thermal resistance between the substrate to header attachment.

$$\theta_{jcStructure} = \theta_{jcSubstrate} + \theta_{jcInterface} + \theta_{jcHeader}$$

PACKAGE FOR HIGH CURRENT MODELS

To maintain maximum reliability, Cougar recommends using our 2-stage Power Pack SMA housing (A2P) for single amplifiers or the 4-stage Power Pack (A4P) for cascaded combinations drawing more than 200 mA total current. If you have questions consult the factory.

DEVICE HANDLING AND ESD PRECAUTIONS

When transporting, installing, and testing hybrid components, Cougar recommends extreme care and caution when handling our hybrid packages (e.g., SMTO-8, TO-8). These packages are highly sensitive to electrostatic discharge (ESD) and contain extremely fragile leads, which can be easily bent or damaged. An ESD exposure can degrade performance or result in complete failure. Refer to MIL-STD-1686 for appropriate ESD procedures and precautions.



POWER PACK SMA

RF AND DC GROUNDING

Amplifiers in hybrid packages (e.g., SMTO-8, TO-8) use the package case for RF and DC grounding. Cougar recommends mounting these packages by placing the case in intimate contact with a good RF and DC ground (minimum 75% attachment) to ensure RF stability and proper thermal dissipation. Leaving the case suspended above the mounting surface will result in unstable RF performance and higher than normal amplifier case temperature.

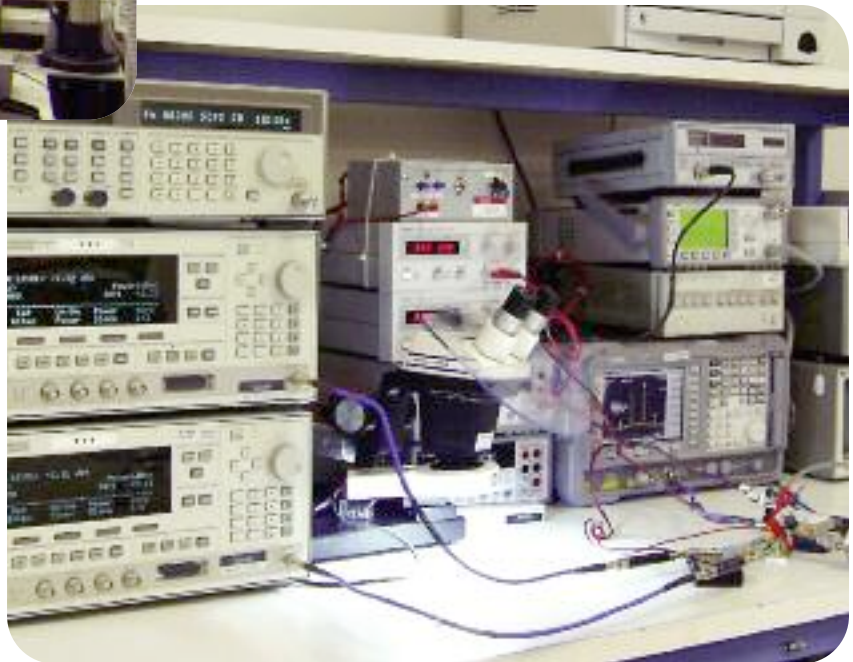

SURFACE MOUNT SOLDER REFLOW ATTACHMENT

The following are recommended guidelines for mounting Teledyne Cougar Surface Mount (SMTO-8 & SMTO-8B) components to printed circuit boards (PCB).

Design Considerations

In order to maintain optimum performance, the RF ground at the backside of the component is critical. Therefore, Cougar recommends that the grounding be achieved per Figures 1 and 2. The 0.025" diameter solder filled vias are spaced in a 0.050" by 0.050" array. The backside of the PCB should be in direct contact with the ground plane to achieve optimum RF performance and provide a thermal path to sink the heat generated by the component. Running traces under the component (multi-layer PCB) is not recommended. The RF and DC interfaces to the component are also shown in Figures 1 and 2.

The information provided in this section is intended only as a guideline and is general in nature. Many other factors must be taken into consideration during the PCB design phase, including but not limited to: specific applications, the end-user's own in-house layout and design rules, actual experience and development efforts for surface mount devices. Additionally, the end user's PCB assembly house should have their own guidelines established for their particular capabilities. Together, these factors will ultimately define the final PCB layout and processes for successful mounting of the surface mount device. Contact Cougar Applications Engineering if there are any specific questions that are not covered in this application note.

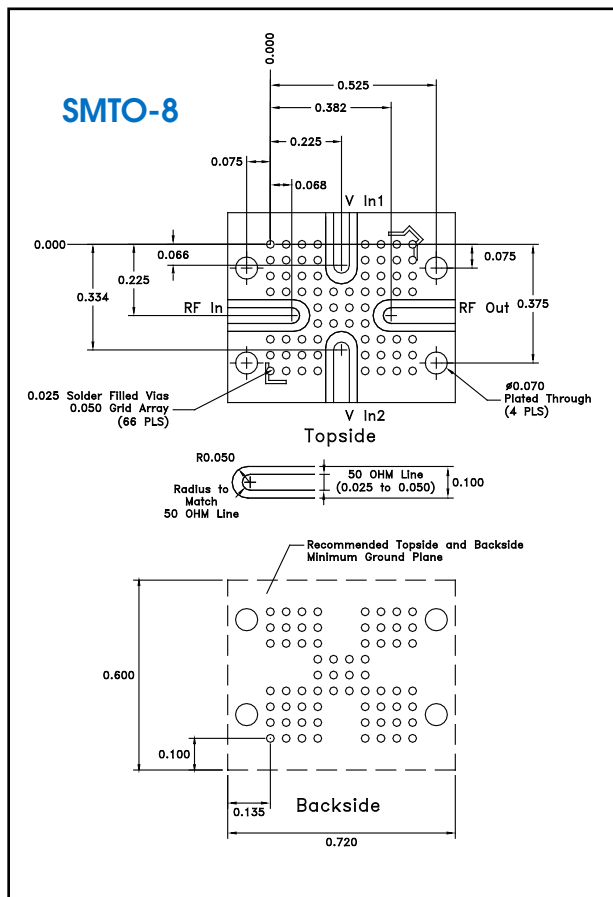

FIGURE 1. Recommended mounting layout for surface mount packages (SMTO-8).

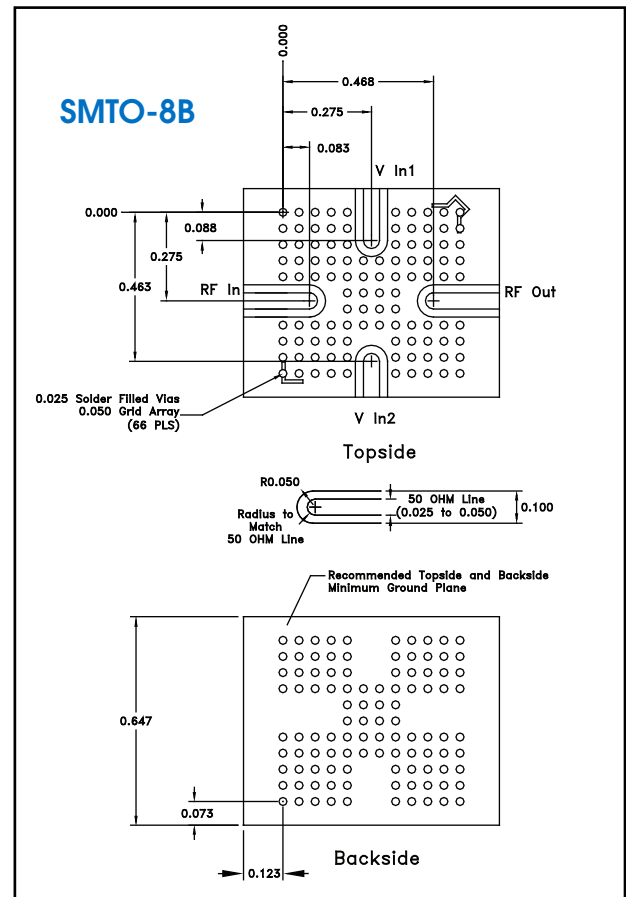

FIGURE 2. Recommended mounting layout for surface mount packages (SMTO-8B).

Figure 3A details the topside view for a four port mounting plane and Figure 3B shows a layout for a grounded component with three ports. Figure 4 shows a typical SMTO-8 and SMTO-8B component in place.

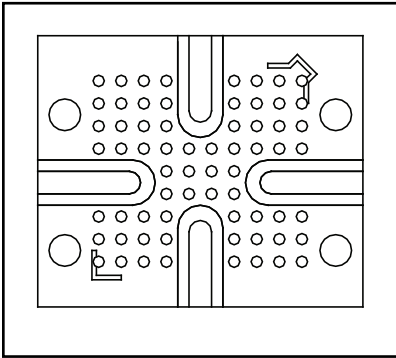

FIGURE 3A. Topside layout for four port.

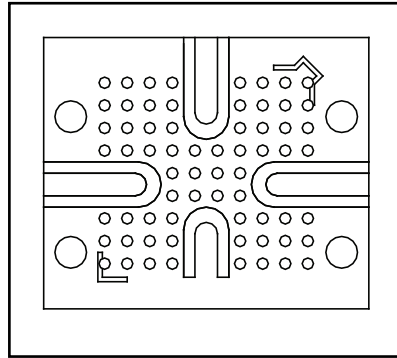

FIGURE 3B. Topside layout for three port.

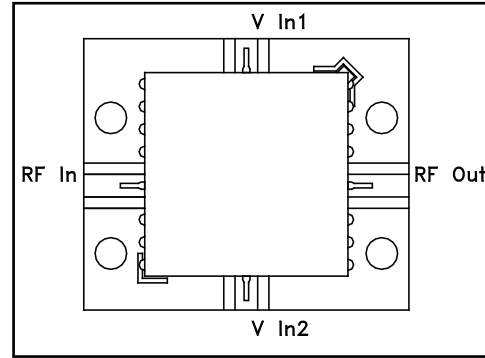

FIGURE 4. Topside with component in place (four port).

Installation Considerations

Cougar recommends using a convection reflow method, using standard conductive, screen printable solder paste (See Figure 5). To enhance this solder flow process, Cougar can supply all surface mount packages pre-tinned. We recommend that the reflow process uses an industry standard reflow system with four heating zones for proper surface mount attachment. The total profile time varies by mass, density and type of reflow equipment. Profile your ovens in a manner that will achieve best reflow results without damaging the circuit. We do not recommend exceeding 200 degrees C for more than 30 seconds, or 235 degrees C peak temperature.

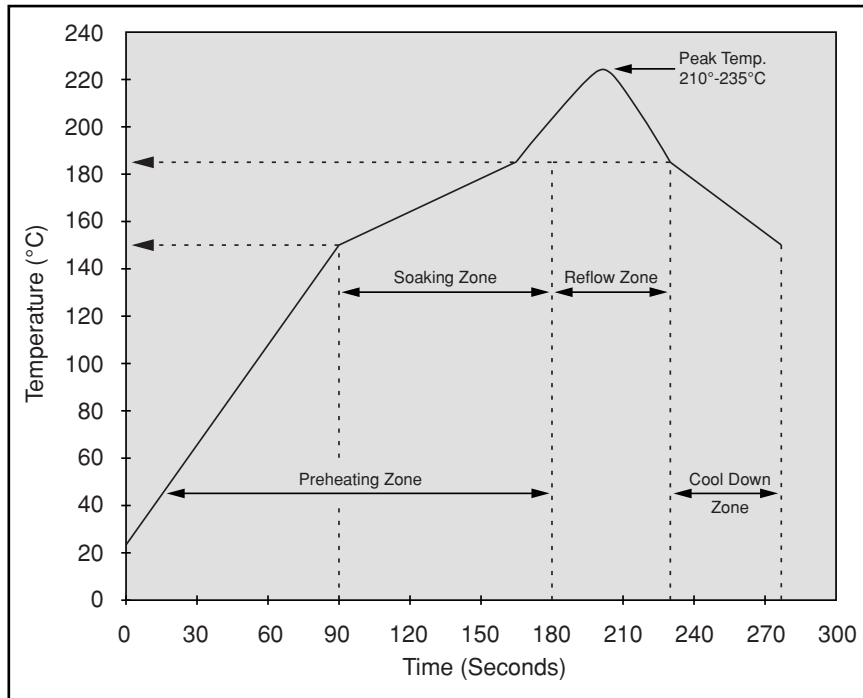
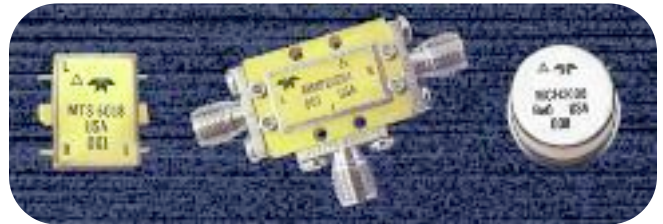

FIGURE 5. Typical reflow profile.

MIXER APPLICATION INFORMATION

Mixer Ports: The input/output terminals of a mixer, are identified as RF, LO and IF. In most double balanced mixers, the LO and RF ports are either transformer or transmission line-couples to the mixer diodes, and therefore have a limited low-frequency response while the IF port is usually direct-couples with an essentially unlimited low frequency response. In upconverting application, the low frequency input signal is often applied to the IF port with the higher-frequency output signal being taken from the RF port.

Mixing: The generation of sum and difference frequencies resulting from applying two AC waveforms to a nonlinear circuit element. In mixer applications, with a signal of frequency f_{RF} applied to the RF port and a signal f_{LO} applied to the LO port, the resulting signal at the IF port will consist of two carriers (or sidebands) of frequencies $f_{RF}+f_{LO}$ and $f_{RF}-f_{LO}$ with internally generated LO and RF harmonics.



Conversion Loss: The ratio (in dB) of the IF output power of a mixer to the RF input power. All conversion loss measurements and specifications are normally based on the mixer being installed in a system with wideband 50 ohm resistive terminations on all ports and a stated LO signal power level being applied.

SSB Conversion Loss: In most applications, only one of the signals ($f_{RF}+f_{LO}$) or ($f_{RF}-f_{LO}$) appearing at the IF port of a mixer is of interest, therefore only one of these signals (or sidebands) is considered when determining conversion loss. Single Sideband Conversion loss is 3 dB higher than the conversion loss when both sidebands are considered (Double Sideband Conversion Loss).

Drive Level: The power level of the local oscillator signal applied to the LO port of a mixer. Operation of a mixer with the maximum recommended LO drive level will result in the best two-tone performance lowest conversion loss and flattest conversion loss vs. frequency characteristics. A reduced LO drive level may help reduce mixer-related Intermodulation products and minimize 1/f noise in the output signal. A higher-than recommended LO power level will result in an increased noise figure and higher LO feedthrough at both the RF and IF ports of the mixer.

Isolation: The ratio (in dB) of the power level applied at one port of a mixer to the resulting power level at the same frequency appearing at another port. Commonly specified isolation parameters of the mixers are:

LO to RF port: The degree of attenuation of the LO signal measured at the RF port when the IF port is properly terminated.

LO to IF port: The degree of attenuation of the LO signal measured at the IF port with the RF port properly terminated.

RF to IF port: The degree of attenuation of the RF signal measured at the IF port with the LO port properly terminated.

Normally the inverse isolation characteristics (such as RF to LO, IF to LO and IF to RF) are essentially equivalent in a double balanced mixer.

Harmonic Intermodulation Distortion: The ratio (in dB) of distortion to the IF output waveform caused by mixer-generated harmonics of the RF and LO input signals. This characteristic is extremely dependent on input frequency, RF and LO signal levels and precise impedance characteristics of all terminations at the operating frequency.

Dynamic Range: The range of the RF input power levels over which a mixer can operate within the specified range or performance. The upper limit of the mixer dynamic range is controlled by the conversion compression point (also a function of LO drive level), and the lower limit is set by the mixer noise figure.

Conversion Compression Point (1 dB): The specification which states the RF input power (in dBm) at which the IF output power will increase only 9 dB for a 10 dB increase in RF input power at a stated LO input power level. Under normal operating conditions, with the RF input power level at least 10dB below the LO input power level, the IF power output is a linear function of RF input minus conversion loss.

Conversion compression point provides an indication of the mixer two-tone Intermodulation performance and is usually of the most concern in high level mixing applications.

Intercept Point (3rd Order): The theoretical point in dBm on the RF input vs. IF output curve at which the power levels of the desired IF output signal and third-order Intermodulation products become equal. This parameter is highly dependent on the LO and RF frequency, the LO drive level, and the impedance characteristics of all terminations at the operating frequency.

Two Tone, Third Order Intermodulation Distortion: The total amount of distortion (dB relative to desired waveform) to the output signal waveform that exists when two simultaneous input frequencies are applied to the RF port of a mixer. Two tone, third order Intermodulation distortion products are described by $(2f_{R2}-f_{R1}) \pm f_{LO}$ and $(2f_{R1}-f_{R2}) \pm f_{LO}$. The higher the third-order intercept point and conversion compression points of a mixer, the lower will be the Intermodulation for given input signal levels.

Cross Modulation Distortion: The amount of modulation impressed on an unmodulated carrier when a modulated signal is simultaneously applied to the RF port of a mixer under specified operating conditions. The tendency of a mixer to produce cross modulation is decreased with an increase in conversion compression point and intercept point.

Desensitization: The compression in the IF output power from a desired RF input signal caused by a second high level signal being simultaneously applied to the RF port of a mixer. As a rule of thumb, in low level mixers, an undesired RF input 3 dB below the mixer conversion compression point will begin to cause desensitization.

OSCILLATOR APPLICATION INFORMATION

VCO: The output frequency of the oscillator is determined by a DC control voltage. Hence VCO or Voltage Controlled Oscillator. The applied voltage tunes the oscillator over a specified frequency range.

Frequency Tuning: The frequency range the tuning voltage will tune a given VCO. Usually graphed as Frequency vs Tuning Voltage.

Frequency vs Temperature: The frequency variation or drift of a VCO over temperature at a DC control voltage.



Power Output: The output power of the oscillator, expressed in dBm and measured into 50 ohms.

Power Output Variation: The maximum to minimum power output variation over a specified frequency range. The power output variation is specified in dB.

Output Power vs Temperature: The output power of the oscillator specified over a specific temperature range expressed in dB.

Tuning Linearity: The deviation of the frequency versus tuning voltage from a given line. In most cases the given line is best fit straight line but could be an absolute straight line as well. The deviation can be expressed in MHz or %.

Modulation Sensitivity: The slope of the frequency vs tuning voltage curve expressed in MHz/V. The modulation sensitivity ratio is the maximum mod. sense divided by the minimum mod. sense over a specified frequency range.

Monotonic Tuning: The oscillator is monotonic if the frequency is always increasing with tuning voltage. Another way to determine monotonic tuning is modulation sensitivity is a positive number.

Tuning Speed and Post Tuning Drift: Tuning speed is the time required to settle the frequency to some percentage of the final frequency after applying a step in the tuning voltage. Expressed in units of time (usec, secs, etc). Post Tuning Drift is the frequency error compared to a final stabilized frequency at a specified time after a step in the tuning voltage. Expressed in units of frequency (Hz, kHz, etc)

VCO Input Capacitance: The total equivalent capacitance seen at the tuning voltage input.

Modulation Bandwidth: The modulation frequency at which the frequency deviation degrades by 3 dB. The modulation source is typically 50 ohms.

Frequency Pushing: The change in output frequency versus supply voltage at a fixed tuning voltage. Expressed in MHz/V.

Frequency Pulling: The change in output frequency due to changes in output load. Specified with a load VSWR of 1.67:1 and expressed in MHz.

Harmonics: Harmonic levels measured with respect to the fundamental signal and expressed in dBc. A harmonic signal can be an integer of the fundamental for a fundamental oscillator. A push push oscillator will also have a 1/2 or 3/2 harmonic signal.

Spurious: Spurious signals are unwanted or non-harmonically related signals present at the output of the oscillator. Spurious response is expressed in dBc similar to harmonic measurements.

Phase Noise (SSB): Single Side band phase noise is a measurement of the carrier noise measured in a 1 Hz bandwidth at some offset of the fundamental signal. The SSB is expressed in dBc/Hz.

IQM PRODUCTS APPLICATION INFORMATION

IQM PRODUCTS

This brief describes the use of Teledyne Cougar's IQM products in four different applications. These are: (1) QPSK modulator, (2) QPSK de-modulator, (3) image reject mixer, and (4) single sideband up-converter. These products provide significant advantages over a double balance mixer performing the same function. We begin by comparing the double balanced mixer to the IQM product.

Comparison to Double Balanced Mixer:

A double balanced mixer can be used in the following four ways: (1) modulator, (2) de-modulator, (3) down converter and (4) up converter. For these applications, an IQM product offers capabilities not available with a double balanced mixer. The comparison is summarized in Table 1 below:

MODE OF OPERATION	DOUBLE BALANCED MIXER	IQM PRODUCT
Modulator	Bi-phase shift key (BPSK)	Quadra-phase shift key (QPSK)
De-modulator	BPSK de-modulator	QPSK de-modulator
Down Converter	Double sideband down converter	Image reject down converter
Up Converter	Double sideband up converter	Single sideband up converter

IQM PRODUCT TABLE 1

(1) Modulator

An IQM product provides four phase steps in 90 degree increments, as opposed to only two 180 degree steps offered by a double balanced mixer.

(2) De-modulator

An IQM product can de-modulate an arbitrarily phase modulated signal, as opposed to a double balanced mixer which is limited to two 180 degree phase states.

Also, while both schemes require a coherent reference signal, the IQM product does not require its phase to be precisely set, as is the case with a double mixer. For this reason, an IQM product is often used even in a BPSK modulated systems.

(3) Image reject mixer

A double balanced mixer will down convert both the desired signal as well as interfering signals in the image frequency band, whereas an IQM product provides significant rejection of the image. It does require an external 90 degree coupler, however.

(4) Single sideband up converter

A double balanced mixer will up convert both upper and lower sidebands equally, requiring a filter to suppress the unwanted sideband. With an IQM product, the designer can choose which sideband to up convert, and which sideband to suppress. An external 90 degree coupler is required for this function.

Block Diagram:

The block diagram is shown in figure 1 - right:

This product consists of a 90 degree power splitter/combiner, two double balanced mixers, and an in-phase power splitter/combiner.

IQM Application:

This section describes the use of an IQM product in four different applications.

(1) QPSK Modulator

In a QPSK modulator, an incoming signal can be phase shifted in 90 degree increments by means of a two-bit signal applied to the I and Q ports. The incoming signal can be applied to either the RF or LO port, while the output appears at the other (RF or LO) port. The I and Q port is biased typically at +20 mA or -20 mA. These bias conditions are referred to as logic "high" or logic "low" respectively. This results in the following four possible (I, Q) combinations: (high, high), (high, low), (low, low), and (low, high). These four logic states correspond to the four 90 degree phase states.

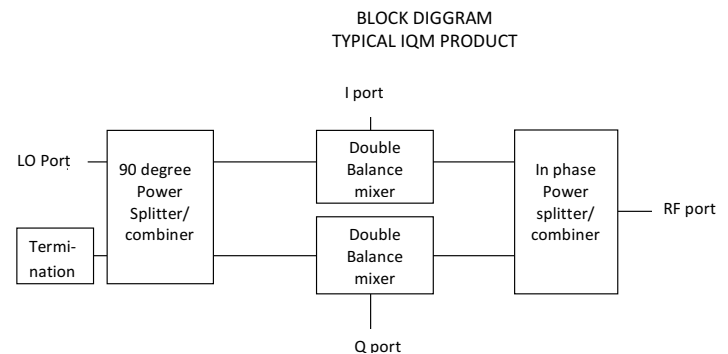

IQM PRODUCT FIGURE 1

(2) QPSK De-modulator

In a QPSK de-modulator, a QPSK modulated signal is applied to the RF (Or LO) port. A second un-modulated signal but phase coherent to the modulated signal is applied to the LO (Or RF) port. The I and Q ports are outputs from which phase information can be derived. The equation that calculates the phase is:

$$\text{Phase} = \arctan(I/Q)$$

(3) Image Reject Mixer

For this application, an external 90 degree equal amplitude power combiner as shown in Figure 2 is required. In this configuration, the combiner is connected in a way so that the phase of the Q port output lags the phase of the I port's output by 90 degrees.

As shown in Figure 2, the Local Oscillator (at frequency F_{LO}) is applied to the LO port. It is desired to down convert a signal at frequency $F_{LO}-\Delta F$ to an intermediate frequency of ΔF , while providing high rejection at the image frequency of $F_{LO}+\Delta F$. This is called the low side down conversion.

For high side down conversion, the ΔF output and the termination switch places. In this case, the $F_{LO}+\Delta F$ signal is down converted while providing high rejection at its image at $F_{LO}-\Delta F$.

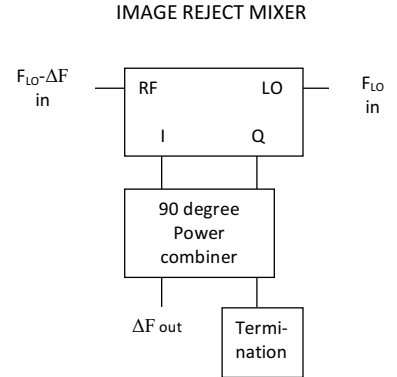

IQM PRODUCTS FIGURE 2

(4) Single sideband up-converter

Here, an external 90 degree power splitter as shown in Figure 3 is required.

This up-converts an IF signal at frequency ΔF to a frequency $F_{LO}+\Delta F$ with a Local Oscillator at F_{LO} while providing high rejection of the opposite sideband of $F_{LO}-\Delta F$. This is called high side up-conversion. For low side up-conversion, the ΔF input port trade places with the termination.

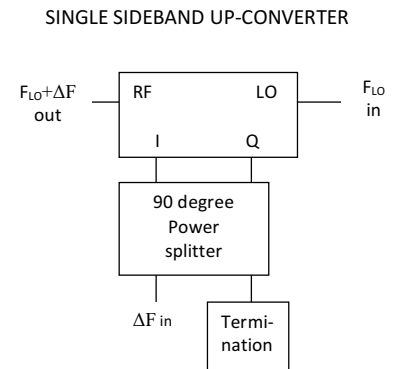

IQM PRODUCTS FIGURE 3